

REINHOLD ENVIRONMENTAL®



2022 Reinhold/PCUG Round Table Presentation

Hosted by Duke Energy in the Charlotte Sheraton/Le Meridien
Hotel, Charlotte, NC on June 27-28, 2022

All presentations posted on this website are copyrighted by **REINHOLD ENVIRONMENTAL®** (RE). Any unauthorized attempts to print, to download, to modify, to incorporate into other presentations, to link to other websites or to obtain copies for any other uses than the training of attendees to RE Conferences is expressly prohibited unless approved in writing by RE or the original presenter. RE does not assume any liability for the accuracy or contents of any materials in this library which were presented and/or created by persons who were not employees or subcontractors of RE.

AdvX[®]-FLX

X-Ratio Management for Operational Flexibility



Reinhold Conference – June 27, 2022

Roadmap

1. *Introduction*
2. *Operational Constraints*
3. *AdvX[®]-FLX*
4. *Case Studies*
5. *Heat Rate*
6. *Q&A*

Steven Kosler, PE

Business Development Manager – AdvX[®]
steven.kosler@ljungstrom.com
512.608.8468

WHAT IS AdvX[®]?

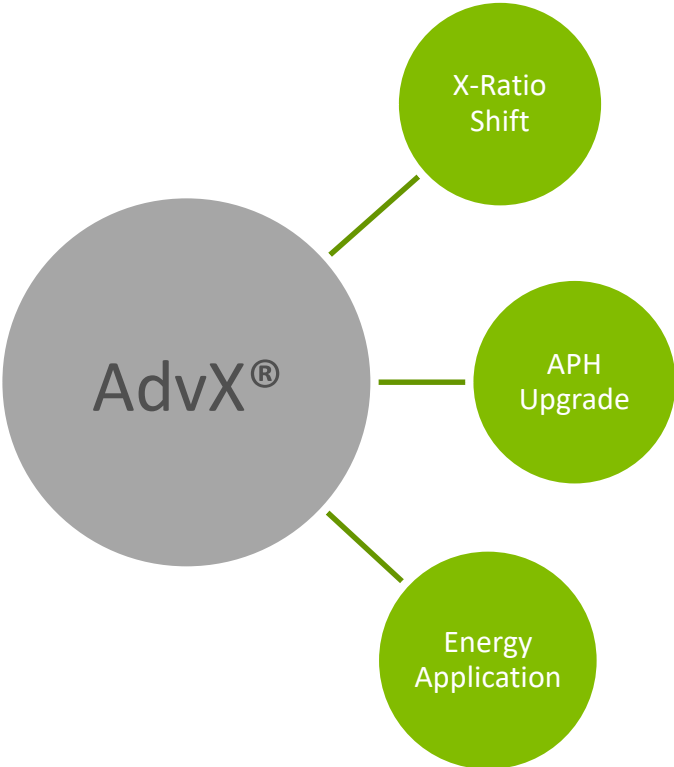

DN8[™]

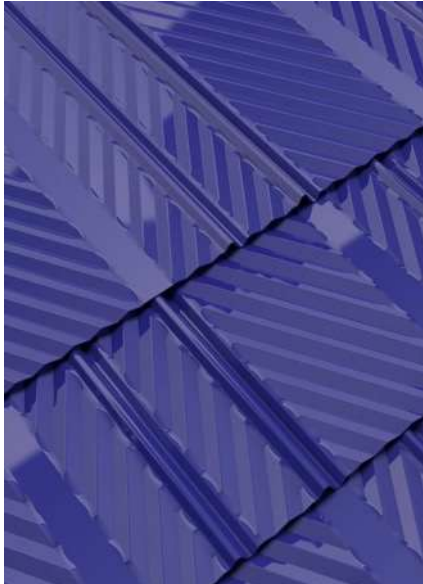

TF4[™]

AdvX[®] PRODUCTS

LJUNGSTRÖM



AdvX[®]-ZLD

Zero Liquid Discharge

ELG compliance with no impact to plant heat rate



AdvX[®]-HRI

Heat Rate Improvements

Enhanced heat recovery and utilization to 5% HRI

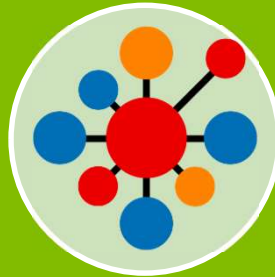

AdvX[®]-FLX

Flexibility

Improved operational flexibility and low load operation



AdvX[®]-ENV

Environmental

Reduce airborne emissions of SO₃, NO_x, PM_{2.5}, and Hg



AdvX[®]-SGR

Stack Gas Reheat

The most efficient way to a clean and dry stack



WE DON'T OPERATE LIKE WE USED TO

LJUNGSTRÖM



- **US Coal Utilities are running at lower loads and capacity factors more often.**
- **Many systems were not designed with low capacity factors in mind.**
- **Cycling and low load operation can introduce operational constraints for APH, mills, SDA, CDS, FGD, etc.**
- **Operational flexibility is becoming more important to deal with changing operations, regulations, fuel availability, etc.**

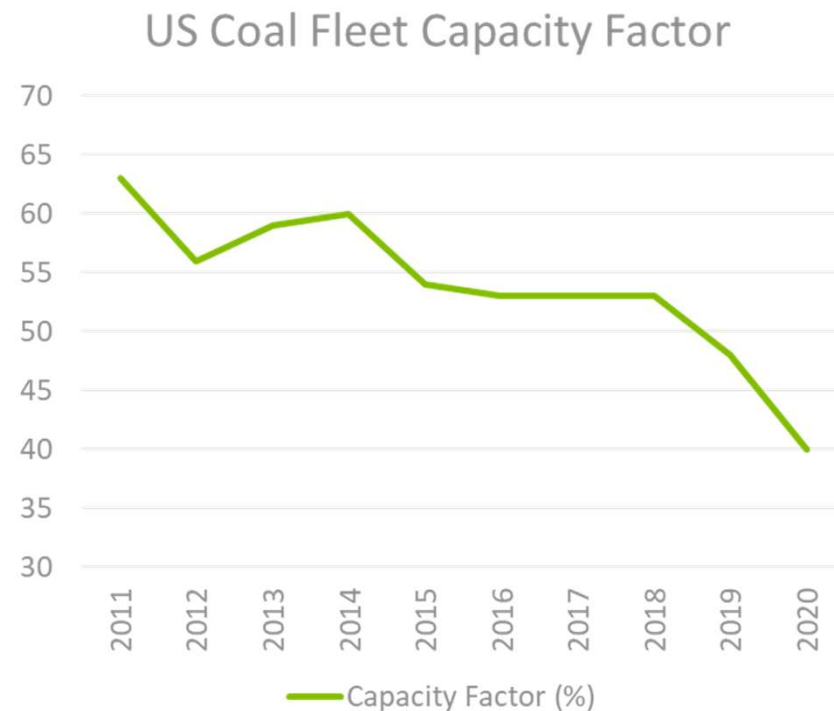

OPERATIONAL CONSTRAINTS

Scrubber (SDA/CDS/FGDw)

1. SO₂ removal
2. Wastewater evaporation capacity
3. Minimum load/temperature/flow

Unit

1. Coal moisture / mill temperature
2. Average cold-end temperatures (ACET)
3. Acid gas dewpoint

As a power plant decreases load, the flue gas flow and temp both decrease – impacting all the above.

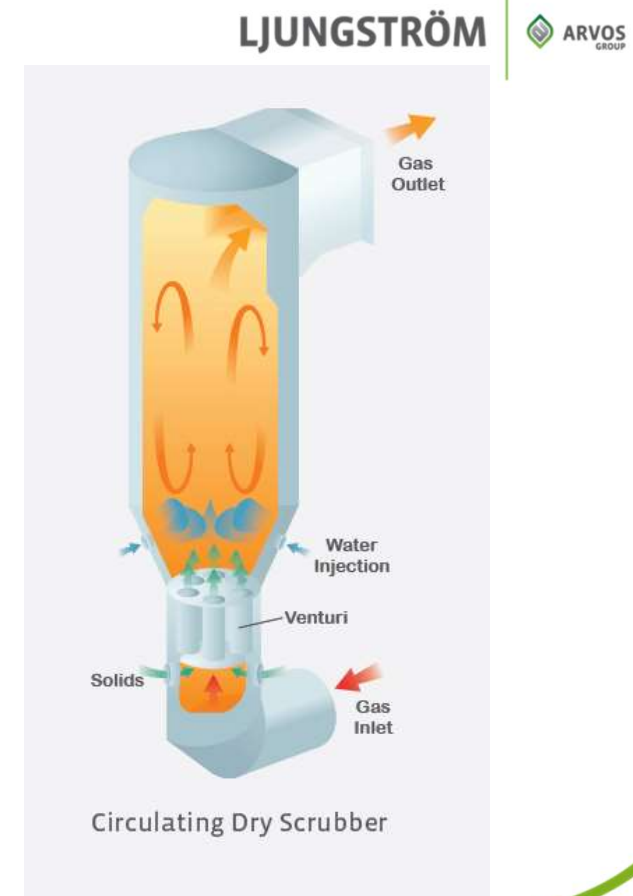

AdvX[®] HEAT RECOVERY SOLUTIONS

LJUNGSTRÖM



AdvX[®]-FLX is a patented, simple, low-cost **SYSTEM** that employs x-ratio management and APH upgrades to mitigate operational constraints.

What is X-Ratio?

$$\frac{\text{Air Flow} \times C_{p_{\text{air}}}}{\text{Gas Flow} \times C_{p_{\text{gas}}}}$$

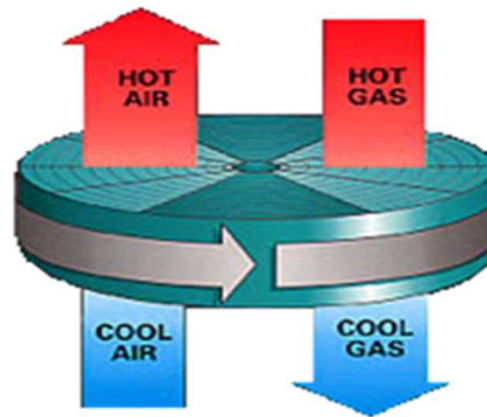

AdvX[®]-FLX utilizes bypass air for Operational **Flexibility**.

AdvX[®]-FLX EXAMPLE (TRI-SECTOR)

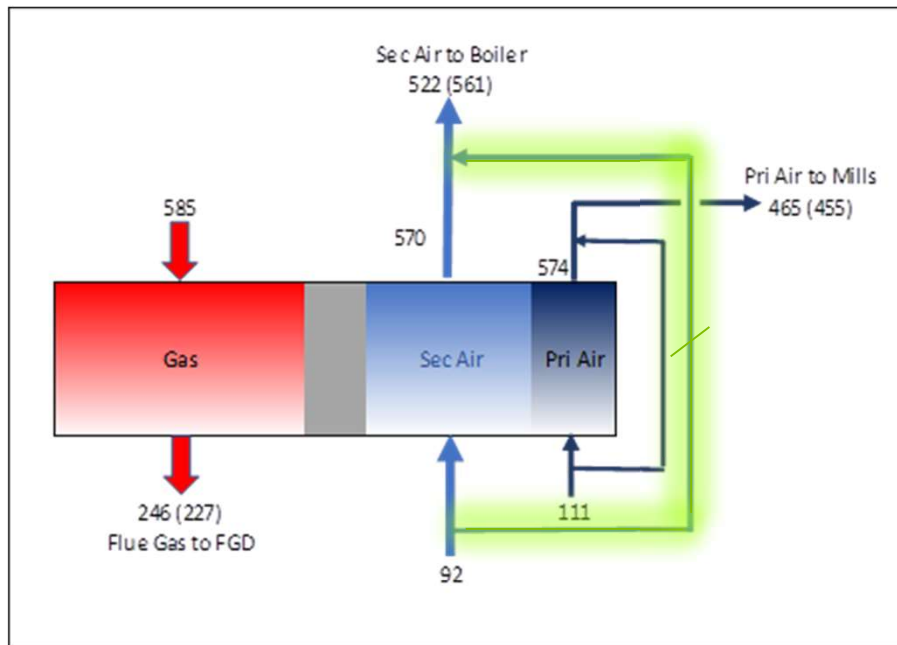

Temperatures shown (before) and after modification

AdvX[®] FLX

Typical Scope of Work

- Secondary air bypass duct
- Control damper
- APH upgrade

Performance

- ✓ Temp increase in Flue Gas Outlet
- ✓ Temp increase in Primary Air
- ✓ ACET increase
- ✓ Acid dewpoint approach increase
- ✓ Negligible change in dP
- ✓ HRI at low load offset at high load.

AdvX[®]-FLX EXAMPLE (BI-SECTOR)

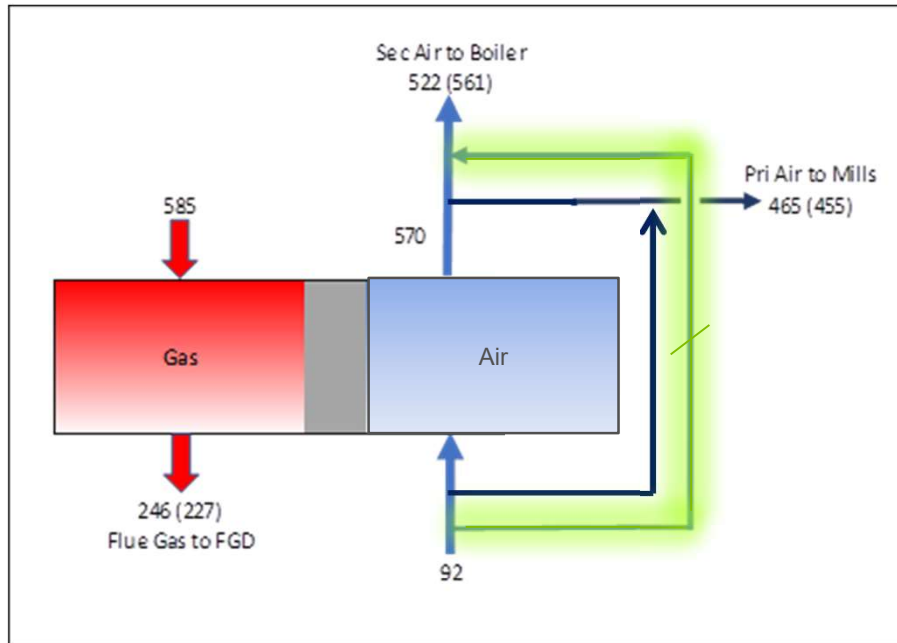

Temperatures shown (before) and after modification

AdvX[®] FLX

Typical Scope of Work

- Air bypass duct
- Control damper
- APH upgrade

Performance

- ✓ Temp increase in Flue Gas Outlet
- ✓ Temp increase in Primary Air
- ✓ ACET increase
- ✓ Acid dewpoint approach increase
- ✓ Negligible change in dP
- ✓ HRI at low load offset at high load.

AdvX[®]-FLX EXAMPLE (SEPARATE PRI/SEC APH)

LJUNGSTRÖM

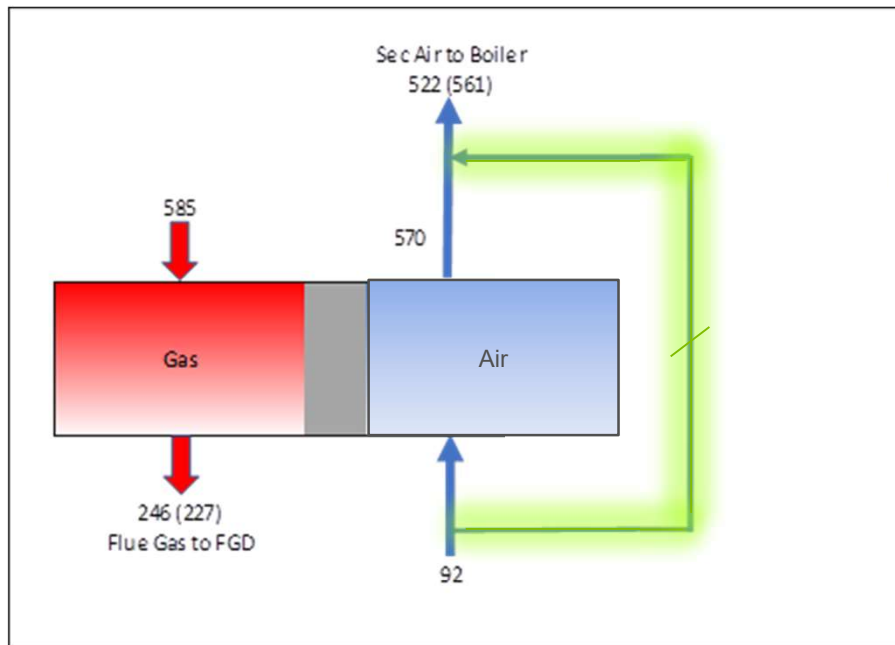

Temperatures shown (before) and after modification

AdvX[®] FLX

Typical Scope of Work

- Secondary air bypass duct
- Control damper
- APH upgrade

Performance

- ✓ Temp increase in Flue Gas Outlet
- ✓ ~~Temp increase in Primary Air~~
- ✓ ACET increase
- ✓ Acid dewpoint approach increase
- ✓ Negligible change in dP
- ✓ HRI at low load offset at high load.

SCRUBBER OPERATIONAL CONSTRAINTS, 1

LJUNGSTRÖM



SO₂ Removal

Problem: We cannot increase reagent to our scrubber due to outlet temperature constraints.

- Outlet temperature controlled by approach to saturation
- Fixed in/out flue gas temps limits reagent slurry capacity
- At lower load, flue gas inlet flow and temp decrease

AdvX[®]-FLX

- Secondary air bypass results in less mass available for heat transfer, resulting in flue gas outlet temp increase.
- Increases flue gas temperature to scrubber, increasing the amount of slurry or humidity that can be injected.

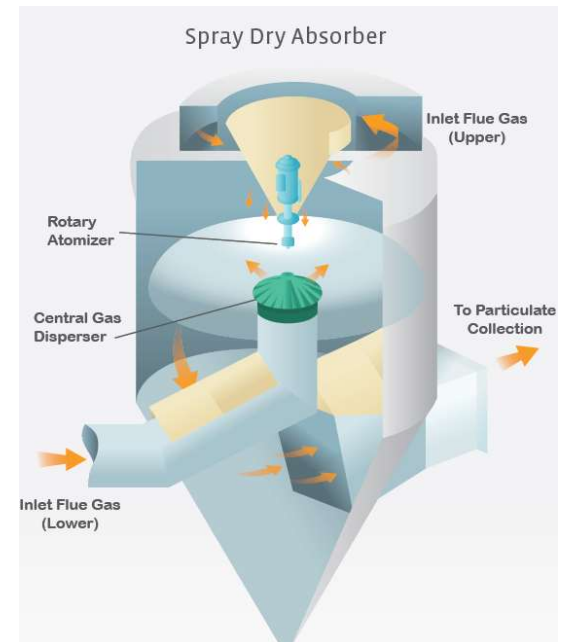

SCRUBBER OPERATIONAL CONSTRAINTS, 2

Wastewater (process water) evaporation capacity

Problem: We cannot evaporate enough process water to maintain ZLD operation – requiring expensive treatment.

- Outlet temperature controlled by approach to saturation
- Fixed in/out flue gas temps limit water evap capacity
- At lower load, flue gas inlet flow and temp decrease

AdvX[®]-FLX

- Secondary air bypass results in less mass available for heat transfer, resulting in flue gas outlet temp increase.
- Increases flue gas temperature to scrubber, increasing the amount of process water that can be injected
- Effective at all loads if capacity needed at full load.

LJUNGSTRÖM

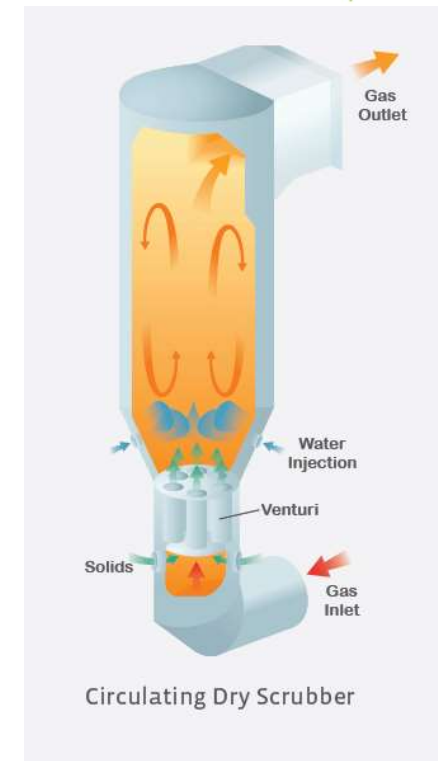

SCRUBBER OPERATIONAL CONSTRAINTS, 3

LJUNGSTRÖM



Minimum Load / Temperature / Flow

Problem: We cannot reduce our minimum load because we cannot bring our SDA/CDS online without sufficient temp or flow.

- SDA/CDS require a minimum load or temperature
- CDS require a minimum flow to keep the bed circulating
- At lower load, flue gas inlet flow and temp decrease

AdvX®-FLX

- Secondary air bypass results in less mass available for heat transfer, resulting in flue gas outlet temp increase.
- Increases flue gas temperature to scrubber, reducing the minimum load required to operate.
- Separate arrangement to increase gas flow available.

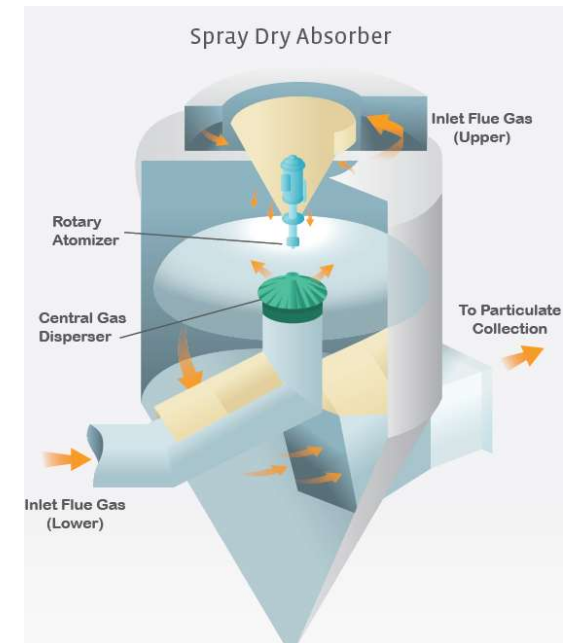

UNIT OPERATIONAL CONSTRAINTS, 1

LJUNGSTRÖM



Coal Moisture / Mill Temperature

Problem: We have difficulty maintaining mill temperatures causing wet coal issues.

- At lower load, flue gas inlet flow and temp decrease
- Lower flue gas temp results in lower air temps from APH
- May not solely be a low-load issue or solution

AdvX®-FLX

- Secondary air bypass results in more heat transfer to primary air, resulting in increased primary air temperature
- Increases primary air temperature to mills, increasing coal drying and mill outlet temperature.

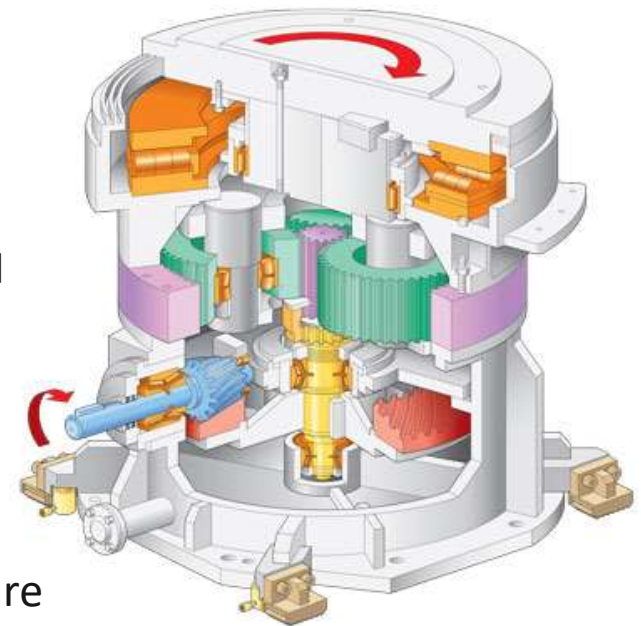

UNIT OPERATIONAL CONSTRAINTS, 2

Average Cold End Temperature (ACET)

Problem: We are corroding our APH faster due to lower capacity factors.

- At lower load, flue gas inlet flow and temp decrease
- Lower flue gas temp results in lower APH gas out temps
- Lower gas outlet temps result in lower ACET

AdvX[®]-FLX

- Secondary air bypass results in less mass available for heat transfer, resulting in flue gas outlet temp increase.
- Increases APH gas outlet temperature, increasing average cold-end temperature.

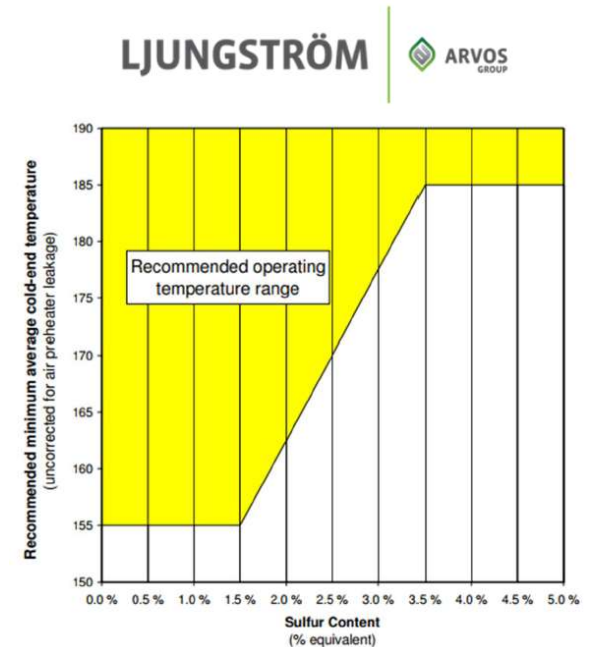

$$ACET = \frac{Temp_{air-in} + Temp_{gas-out}}{2}$$

UNIT OPERATIONAL CONSTRAINTS, 3

Acid Dewpoint

Problem: We are corroding our ductwork and equipment downstream of the APH.

- At lower load, flue gas inlet flow and temp decrease
- Lower flue gas temp results in lower APH gas out temps
- Lower gas outlet temps can cause acid condensation

AdvX[®]-FLX

- Secondary air bypass results in less mass available for heat transfer, resulting in flue gas outlet temp increase.
- Increases APH gas outlet temperature, increasing acid dewpoint approach temperature.

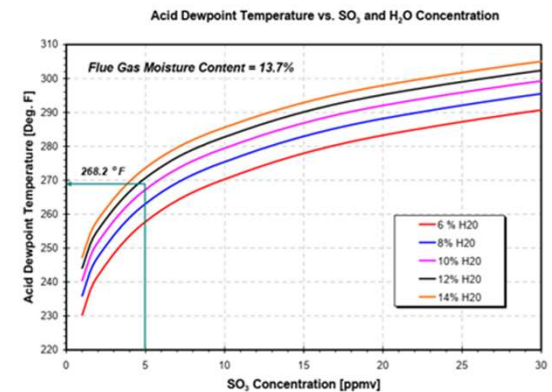

Figure 4-4s: Acid Dewpoint as a Function of SO₂ and H₂O Concentration in the Flue Gas

AIR PRE-HEATER (APH) 101

“Operation of a regenerative APH represents a compromise between performance and maintenance.” – Nenad Sarunac, PhD.

– Increasing Efficiency and Reducing Emissions of Coal-Fired Units, Energy Research Center, 2009

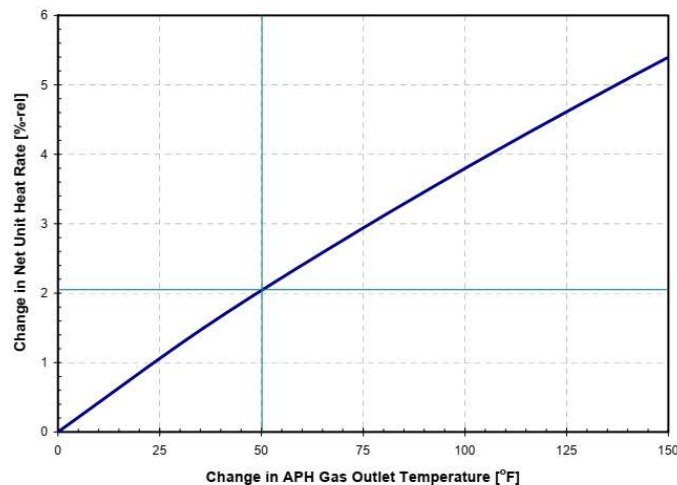

Figure 4-1: Effect of APH Gas Outlet Temperature on Net Unit Heat Rate

AdvX[®]-FLX

- Element upgrade
- Results in Fgo reduction
- 25°F change in Fgo = 1% HR change.
- Close bypass when not required to recover heat rate w/ APH upgrade.
- HRI may require ADP mitigation.

AIR PRE-HEATER (APH) 101. CLASS DISMISSED

“No worries. Remove to improve.”

– Steven Kosler, (not-PhD.) 2019

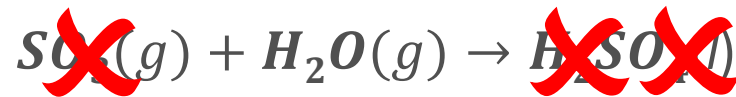
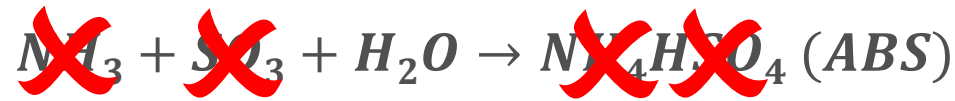

Hydrated Lime DSI for SO₃

By number of systems

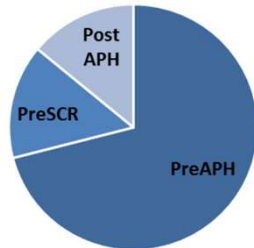

~85% of hydrate DSI units feed prior to APH

Pre-SCR includes units expected to convert in next 6-18 months

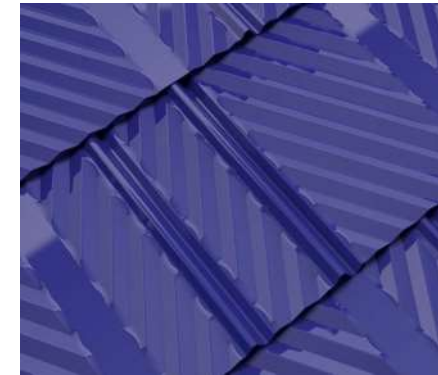

Heat Rate Improvement Options

Heat Rate can be improved by:

1. improving boiler efficiency,
2. improving turbine cycle heat rate, and/or
3. reducing auxiliary power use.

- 1. Boiler efficiency can be improved by:
 - Reducing stack gas losses (using more heat from flue gas).
- 2. Turbine cycle heat rate can be improved by:
 - Reducing steam extraction from turbine cycle.
- 3. Auxiliary power use can be reduced by:
 - Improving equipment efficiency.

AdvX[®]-HRI improves all three.

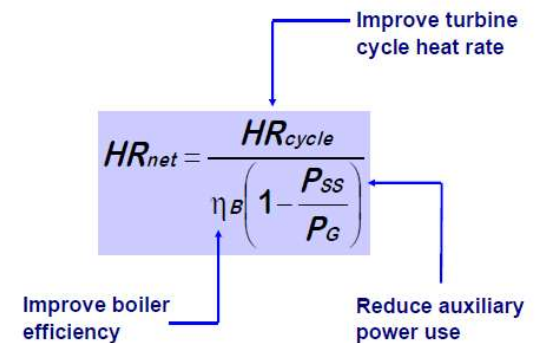

Figure 4: Options for Heat Rate Improvement

CASE STUDY 1

- Boiler efficiency can be improved by:
 - Reducing stack gas losses
- Unit recently relocated their SO₃ control upstream of APH
- Opens up APH upgrade to reduce stack gas losses.
- Max thermal upgrade – 44F GOT reduction
- \$2.5MM/yr/unit savings with APH upgrade alone.
- Acid dewpoint management and APH optimization remains an effective strategy for HRI that many have yet to implement

CASE STUDY 2

- PRB switch w/ >300F APH gas outlet
- Limited APH upgrade potential
 - DL7 for popcorn ash
 - No space for additional depth
 - Thermal upgrade – 2F GOT reduction
- Turbine cycle heat rate can be improved by:
 - Reducing steam extraction from turbine cycle.
 - Seasonal as steam not used in Summer.
 - Reducing steam coil lowers ACET
- What else can be done to reduce GOT and improve heat rate?

LJUNGSTRÖM



AdvX[®]-HRI SYSTEM

Target Criteria

- High stack gas losses (>250F APH Gas Out)
- APH fouling / corrosion / sootblowing frequency (SO₃)
- APH thermally max or ACET/ADP limitations
- Recent SO₃ control relocation to upstream APH

Typical Scope of Work

- SO₃ optimization if nec.
- APH upgrade
- X-ratio shift
 - flue gas bypass duct
 - exp. joint(s) / damper(s)
- Energy application
 - Heat exchanger(s) loop (flue gas to BFW or SAH)
 - Replace/reduce extraction steam

Value Proposition

- Smaller equipment than FGC
- Increases gas side effectiveness of APH
- Up to 3% HRI

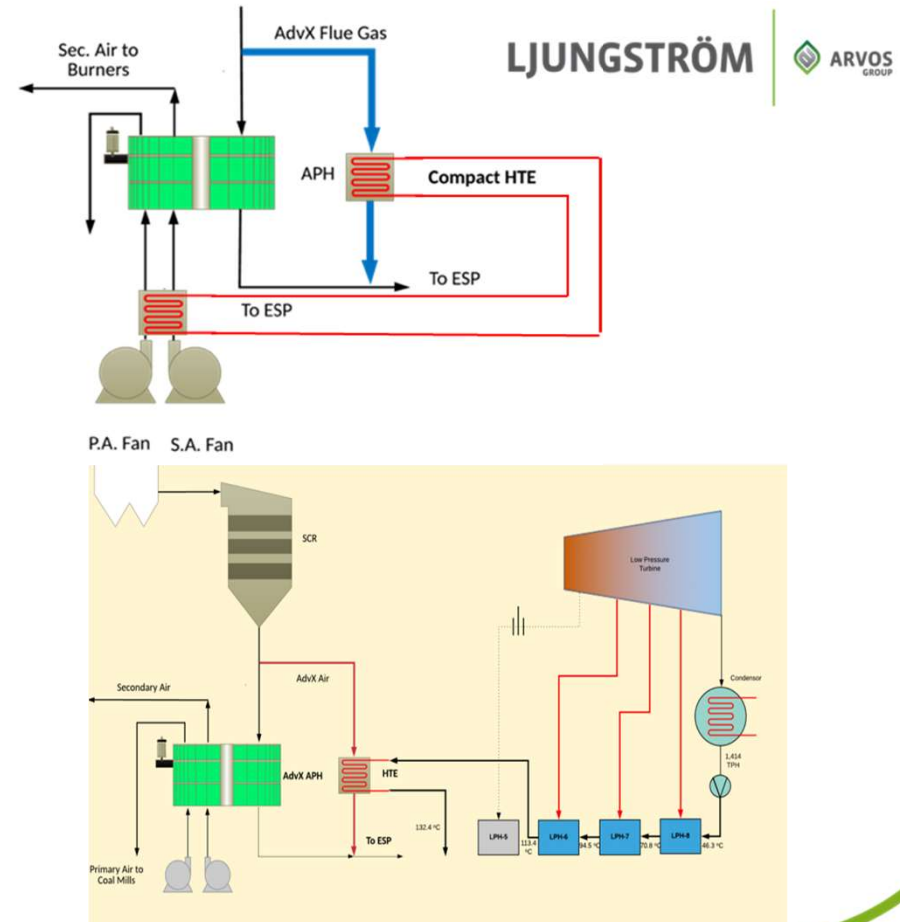

CASE STUDY – ADVX-HRI

ORIGINAL APH

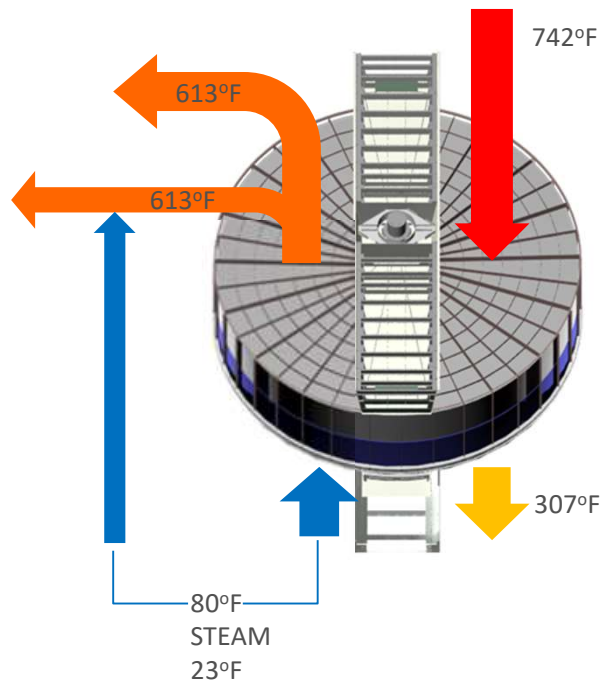

AdvX®-HRI UPGRADE

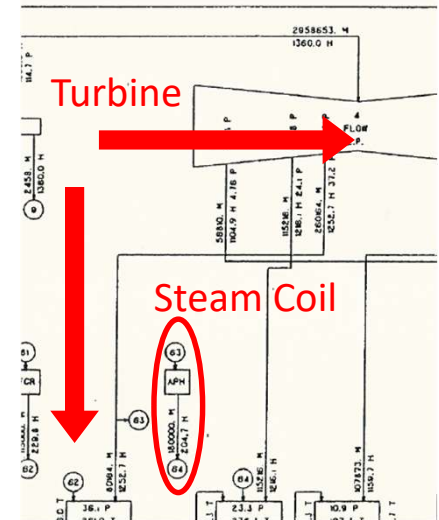
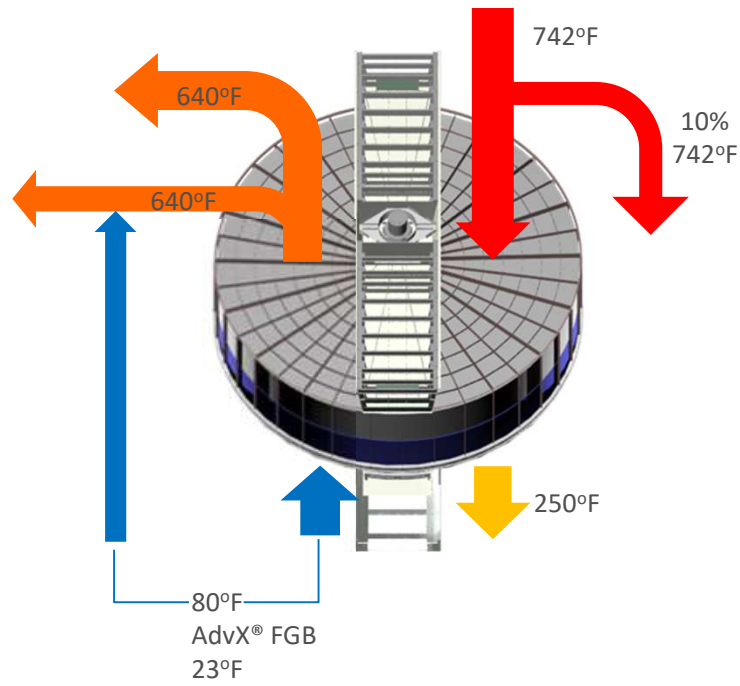

40,000 kg/hr steam
+13MW generation

ADVX-HRI CASE STUDY CONTINUED...

- Boiler efficiency can be improved by:
 - Reducing stack gas losses
 - 307F to 250F
 - -5.5 klb/hr fuel
- Turbine cycle heat rate can be improved by:
 - Reducing steam extraction from turbine cycle.
 - 40,000 kg/hr steam
 - +13MW
- Auxiliary power use can be reduced by:
 - Improving equipment efficiency.
 - Flue gas volume
 - Fan / equipment power
- **3.0% “+” NUHR Improvement**

RESULTS SUMMARY	Baseline	AdvX [®] -HRI	
	100% Steam Extraction	0% Steam Extraction	
Max gross generation	660.04	673.04	MW
Increased Revenue Opportunity		\$ 4,159,486	\$/Year
Fuel Requirement	610.96	605.47	Klb/hr
Cost Savings Opportunity		\$ 1,198,430	\$/Year
Combined MW + Fuel Savings Benefit		\$ 5,357,916	\$/Year

Next Steps

1. **Contact LJUNGSTRÖM sales representative to discuss goals.**
2. **Develop assessment**

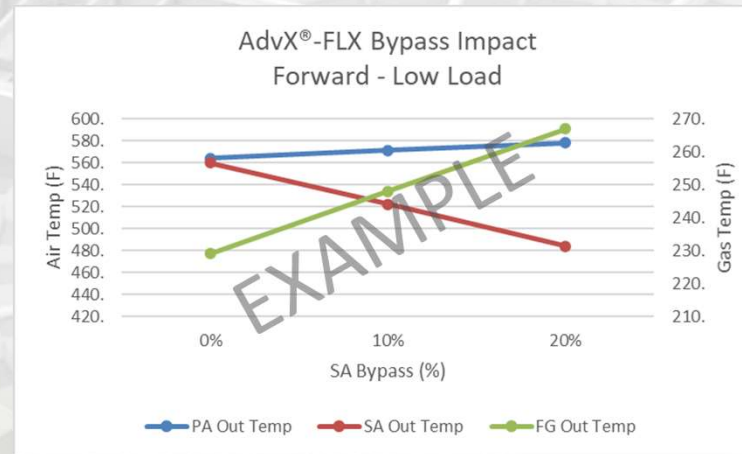
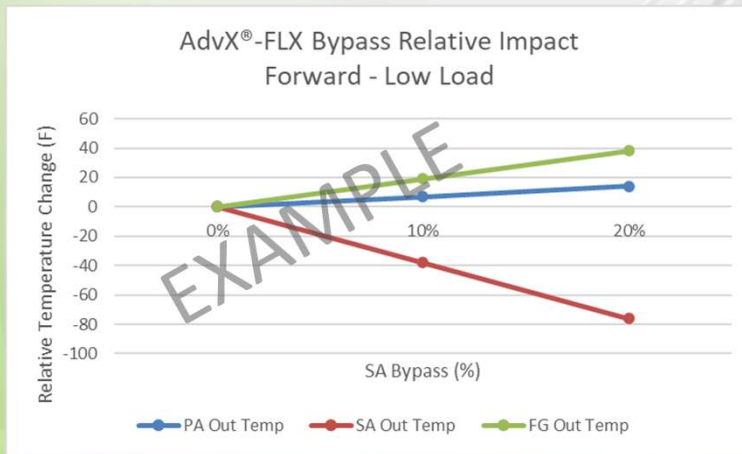

3. **Site visit for sizing and routing**
4. **Issue proposal**
5. **Bypass delivered in ~6months.**

Steven Kosler

Business Development Manager – AdvX®
steven.kosler@ljungstrom.com
 512.608.8468

Get to the point

- 1. AdvX[®]-FLX can mitigate 6 operational constraints all in one simple, low-cost, system.***
- 2. Heat rate improvement when bypass closed via APH upgrade.***
- 3. LJUNGSTRÖM can design, manufacture and install AdvX[®]-FLX for a turn-key solution.***

Steven Kosler

Business Development Manager – AdvX[®]
steven.kosler@ljungstrom.com
512.608.8468

QUESTION & ANSWER

Steven Kosler

Business Development Manager – AdvX®
steven.kosler@ljungstrom.com
512.608.8468

LJUNGSTRÖM



THIS PRESENTATION CONTAINS WITHOUT WARRANTY PROPRIETARY GRAPHICS, TEXT AND/OR CONFIDENTIAL INFORMATION. THE COPYING, PUBLISHING OR DISTRIBUTION OF PROPRIETARY INFORMATION WITHOUT THE PROPRIETOR'S WRITTEN CONSENT IS EXPRESSLY PROHIBITED. COPYRIGHT© 2017 ARVOS